

# NPA

## Surface-Mount Pressure Sensor Series

The NPA product series is provided in a miniature size as a cost effective solution for applications that require calibrated performance. Packaged in a SOIC14 pin surface mount, the NPA Series is available in Gauge, Absolute or Differential pressure ranges with either mV, amplified analog or digital outputs. The sensor is intended for printed circuit board mounting and delivered in optional tape and reel form to simplify manufacturing handling.

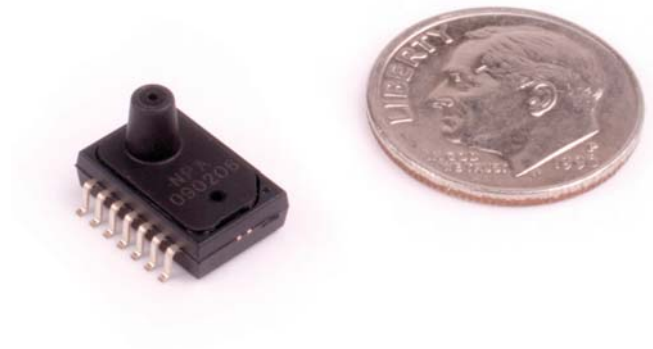

### Features

- Surface Mountable
- Differential, Gauge, Absolute & Low Pressure
- 10" H<sub>2</sub>O to 30 PSI Full Scale
- Analog Amplified Analog or Digital Output
- Uncalibrated mV Output Option
- Digital pressure signal: 14 bit ADC / 11 bit DAC
- On chip temperature sensor in digital mode
- Operating temperature range of -40 to 125°C
- Total Error Band < ±1.5% FSO
- 60X overpressure on ranges <1 PSI



# NPA Preliminary Engineering Specification

Parameter	Value	Units	Notes
<b>Environmental</b>			
<b>Temperature Range</b>			
Operating	-40 to +125	°C	-40 to +257°F
Compensated	0 to 70	°C	+32 to +157°F
Storage	-40 to +125	°C	-40 to +257°F
<b>Mechanical</b>			
<b>Weight</b>	~1	grams	
Media Compatibility			
Positive differential and gage ports	Compatible with exposed materials		1
Negative differential ports	Dry gases only		

Parameter	Units	Min	Typ	Max	Notes
<b>Common Parameters</b>					
Accuracy (Total Error Band)	%FSO	-1.5		1.5	
Response Time	ms		1	2	
Pressure Overload <1psi FS range	full scale		60X		
Pressure Overload 5psi to 30psi	full scale		2X		
Resolution			11bit	DAC	
Pressure ranges		10"H2O		30psi	
<b>Digital Performance</b>					
Resolution			14bit	ADC	16383 steps
Sampling Rate	kHz		1		
Digital Serial Output					
Temperature Sensor Accuracy			4°C		8bit
<b>Analog Performance Parameters 5 volt Excitation</b>					
Offset	Volts	0.44	0.5	0.56	
Span	Volts		4		
<b>Analog Performance Parameters 3.3 volt Excitation</b>					
Offset	Volts	0.46	0.5	0.54	
Span	Volts		2.5		

Notes: 1. Exposed materials are thermoset plastic, silicon, epoxy, RTV, and pyrex.

NPA Uncalibrated Performance			
Parameter	Value	Units	Notes
Pressure Range	0.36 to 30	psi	10"H2O = 0.361psi = 2.49KPa
Excitation	1.5	mA	10 VDC Maximum
Input Impedance	5000±20%	Ω	
Output Impedance	5000±20%	Ω	
Zero Offset	± 75	mV	
Full Scale Output (10"H2O)	40 to 120	mV	
Full Scale Output (1psi)	75 to 135	mV	
Full Scale Output (5 psi to 30psi)	100 to 166	mV	
Full Scale Output (15psi & 30psi)	75 to 135	mV	
Linearity	±0.25	%FSO	
Pressure Hysteresis	±0.02	%FSO	
Temperature Coefficient of Zero	+30	μV/ V / °C	
Temperature Coefficient of Resistance	0.29	% /°C	
Temperature Coefficient of Sensitivity	-0.2	%FSO/°C	
Thermal Hysteresis of Zero	0.2	%FSO	
Position Sensitivity	0.1	%FSO	

Pin #	Uncalibrated Analog	Amplified Digital & Analog	Function Notes
3	VP	--	Sensor Interface Positive Output
4	VSSP	--	Sensor Interface Ground
5	--	--	Not Connected
6	--	VSS	Ground Supply
8	--	SIG	Analog Out, Digital Out, Calibration Interface
9	--	VDD	Supply Voltage
10	--	--	Gate Control for External JFET Regulation / Overvoltage Protection
11	VN	--	Sensor Interface Negative Output
12	VDDP	--	Sensor Interface Positive Excitation

Note: Pin numbers, 1, 2, 7, 13, 14 are unused.

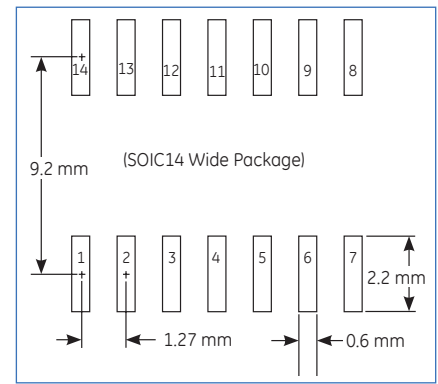

Suggested PCB Land Pattern

### Manifold Design (All measurements given in mm)

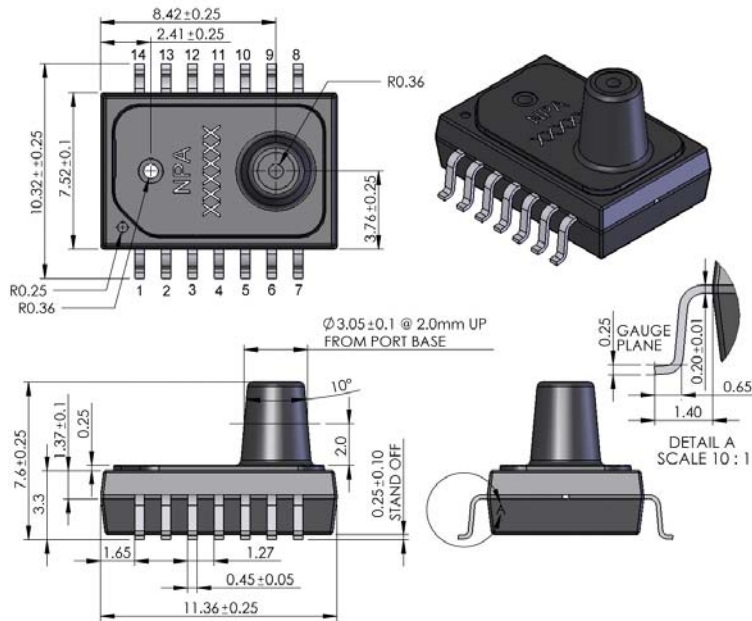

### Barbed Fitting Design

Recommended tubing size of 3/32" ID, 7/32" OD, 1/16" wall thickness

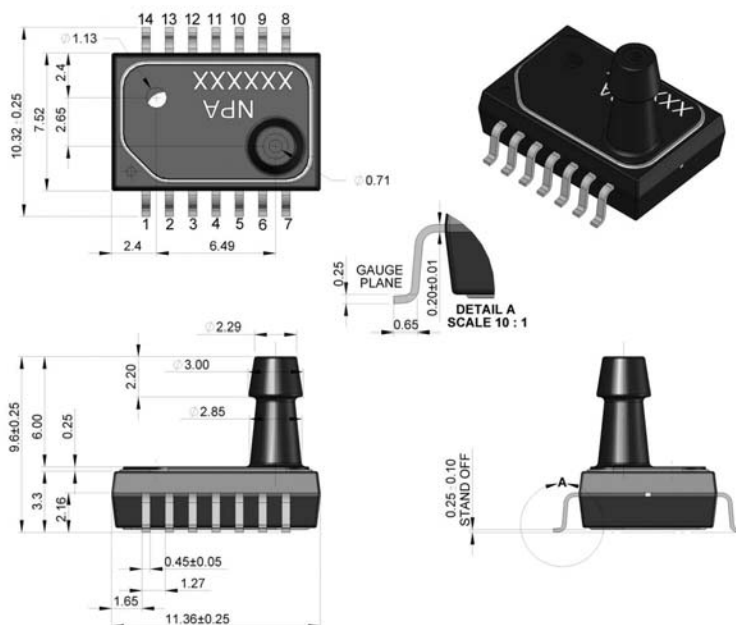

# Typical Analog Circuits

Circuit layout same as "Ratiometric Voltage Output"

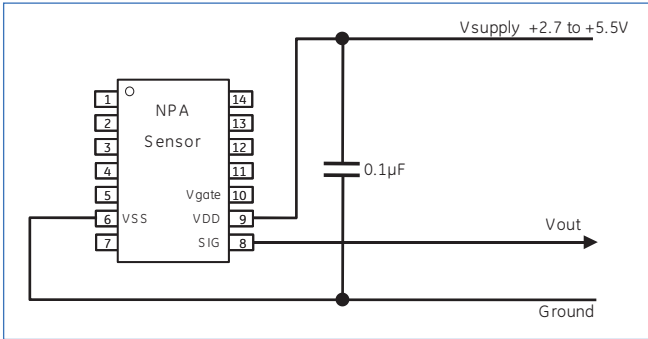

Ratiometric Voltage Output

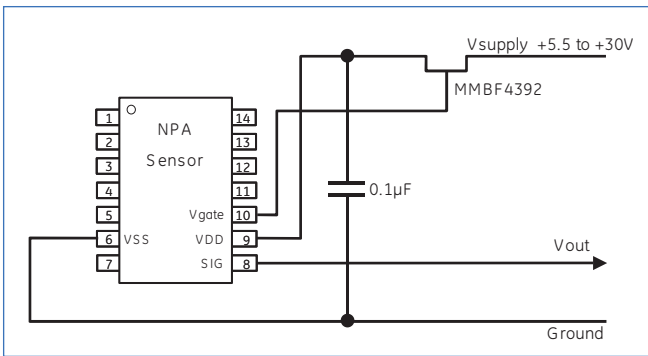

Absolute Voltage Output

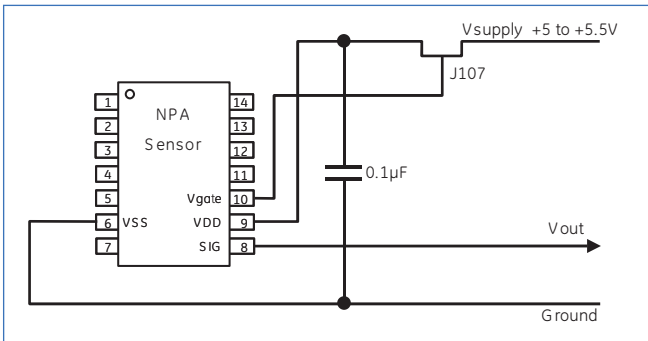

Ratiometric Voltage Output with Over-Voltage Protection

# Digital Output Options

Streaming serial output is a 14 bit number proportional to the full scale

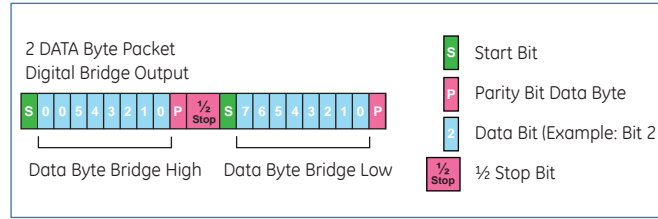

Digital Output (NOM) Bridge Readings

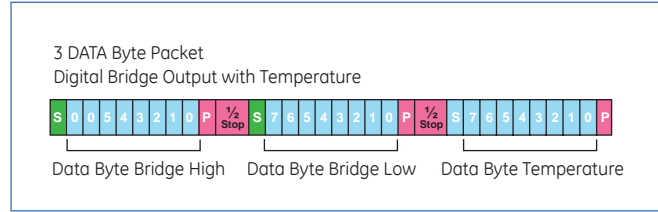

Digital Output (NOM) Bridge Readings with Temperature  
Option: Ask salesperson to stipulate Temperature need

# Ordering Information

Model NPA	Code	Description
	100	mV Output, Ratiometric Uncalibrated sensor
	300	Analog Amplified Output, 3.3Vdc Excitation, Calibrated sensor
	500	Analog Amplified Output, 5Vdc Excitation, Calibrated sensor
	600	Digital Serial Output, Calibrated Sensor
		<b>Code Port Type</b>
	M	Ported Manifold Pressure connection
	B	Barbed Pressure Port
	N	Non ported Manifold
		<b>Code Pressure Range</b>
	010W	10"H2O (2.5 KPa)
	001	1 PSI (7 KPa)
	005	5 PSI (35 KPa)
	015	15 PSI (100 KPa)
	030	30 PSI (200 KPa)
		<b>Code Pressure Type</b>
	G	Gauge
	D	Differential
	A*	Absolute
		<b>Code Description</b>
	Blank	Plastic Pack
	T	Tape and Reel

Note: \* Absolute pressure ranges are available in 15 PSIA and 30 PSIA only. Contact Factory for custom pressure ranges.



www.gesensinginspection.com